

# Training seminar for First level controllers

## Bari, 3 December 2019

### Introduction

MA/JS of the Interreg IPA CBC Italy-Albania-Montenegro  
Mauro Novello JS Coordinator



**Practice makes  
perfect**  
**ENTRY TEST at**  
**[https://forms.gle/Q5  
R8Atik13Mk3bYv5](https://forms.gle/Q5R8Atik13Mk3bYv5)**

## OUR GOAL FOR TODAY



# Increase understanding of programme requirements for FLC

- awareness of key rules
- common understanding
- some answers to some questions

# AGENDA 3 DECEMBER 2019



**09:30** Welcome – entrance test and introduction

**10:00** FCL check lists and eligibility cases

**11:30** Checking public procurement

**13:00** Break

**14:00** On-the-spot checks and quality assurance



# INTRODUCTION

# Global allocation and timeline



Axis	Total budget			
	(Fixed in CP)	First call	Thematic	Targeted call
1 Competitiveness	18.541.511,00	7.044.758,63	11.373.934,39	100.000,00
2 Tourism	25.958.116,00	13.120.337,96	9.488.609,41	3.348.063,90
3 Environment	23.176.890,00	6.286.929,32	11.464.117,54	5.402.034,63
4 Transport	15.760.285,00	4.028.303,33	7.000.000,00	4.731.981,67
<b>TOTAL</b>	<b>83.436.802,00</b>	<b>30.480.329,24</b>	<b>39.326.661,34</b>	<b>13.582.080,19</b>
5 Technical Assistance	9.270.756,00			
<b>TOTAL</b>	<b>92.707.558,00</b>			

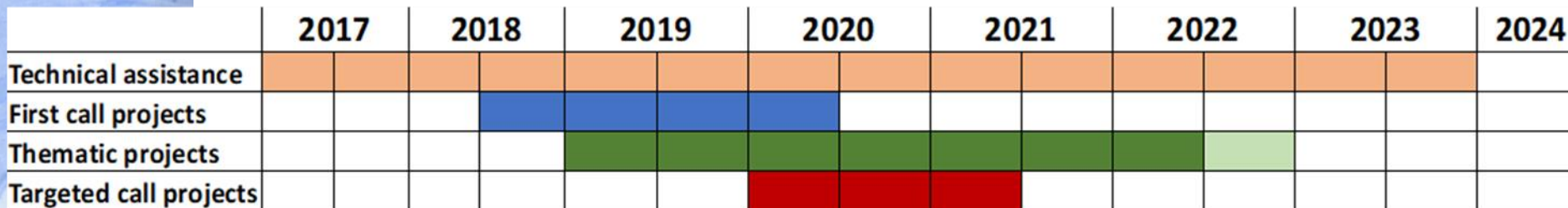

## LEGAL BASIS



- ✓ IPA II (Reg. no. 231/2014)
- ✓ IPA IR (EC Reg. no. 447/2014)
- ✓ CPR (Reg. no. 1303/2013)
- ✓ ETC (Reg. 1299/2013) **article 23 (4)**
- ✓ Financial Regulation (Reg. No 547/2014)
- ✓ Financing Agreements signed between the EC and Albania and Montenegro



- ✓ Programme Manual (factsheets)
- ✓ MEF - IGRUE «CARATTERISTICHE GENERALI DEL SISTEMA NAZIONALE DI CONTROLLO DEI PROGRAMMI DELL'OBIETTIVO COOPERAZIONE TERRITORIALE EUROPEA 2014 - 2020»
- ✓ Description of the Management and Control System



# KEY PARTS OF THE MANUAL FOR FLC



Factsheet no.	Content
4.1	Reporting system, obligations, procedures
4.3	Public procurement, incl. thresholds of the Financial Regulation
<b>4.4</b>	<b>FLC guidelines, incl. audit trail, procedures</b>
4.6	State aid, incl. programme approach
<b>4.8 + Annex</b>	<b>FLC eMS procedures, incl. step-by-step guidance on check lists</b>
4.9 + Annex	Nulla osta procedure
<b>4.10 + Annex</b>	<b>Eligibility rules incl. AUDIT TRAIL + templates for staff reports</b>
4.11 + Annex	Fraud risk management + programme approach

# MANAGEMENT VERIFICATION



## Managing authority / NAs

- ✓ FLC validation (nulla osta) in Italy, appointment in AL and ME by NAs
- ✓ Ensures system works: risk assessment based on-the-spot, quality check
- ✓ Possible withdrawal

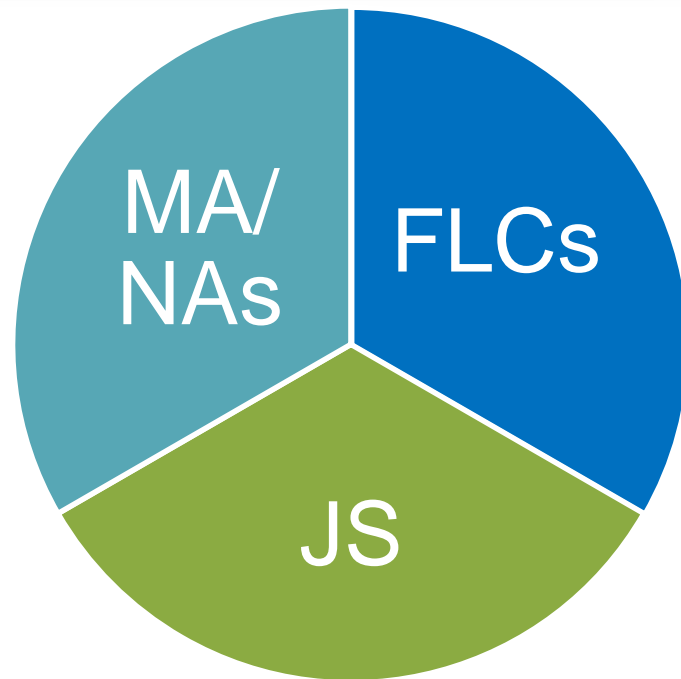

# MANAGEMENT VERIFICATION



## First level controllers main checks:

- ✓ Compliance (EU, national rules)
- ✓ Completeness
- ✓ Reality/existence and Plausibility

## FLC sub-procedures :

- ✓ Inspections of documents
- ✓ Reconciliation/Recalculation
- ✓ Inquiry/interviews
- ✓ On-the-spot verifications

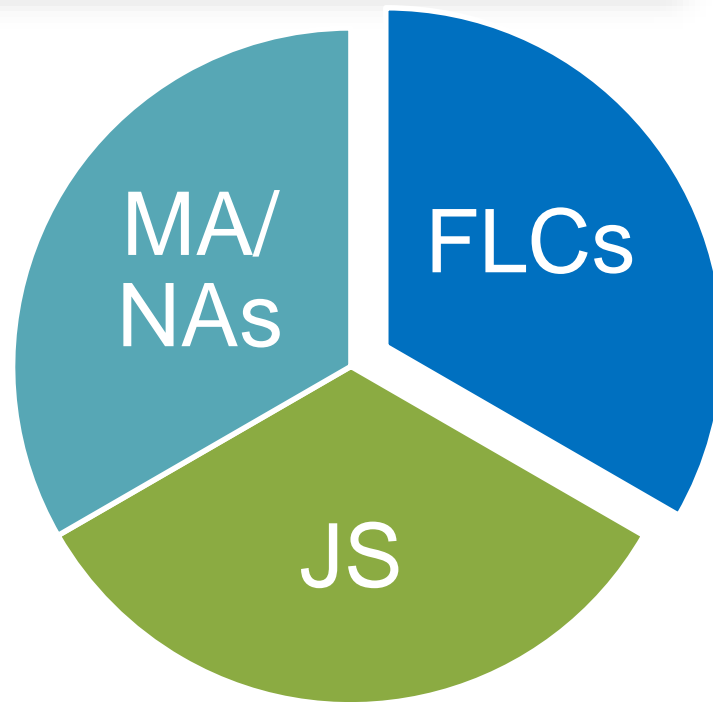



## Joint Secretariat:

- ✓ Progress in relation to plan
- ✓ Suitable outputs / products
- ✓ Expected results reached
- ✓ Project visit (at least once with the mid-term review)

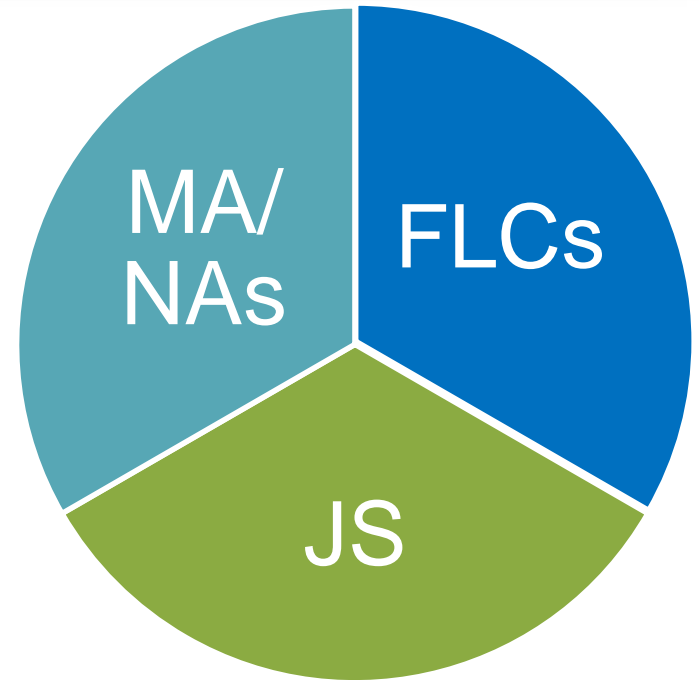

# REPORTING - PAYMENT FLOWS

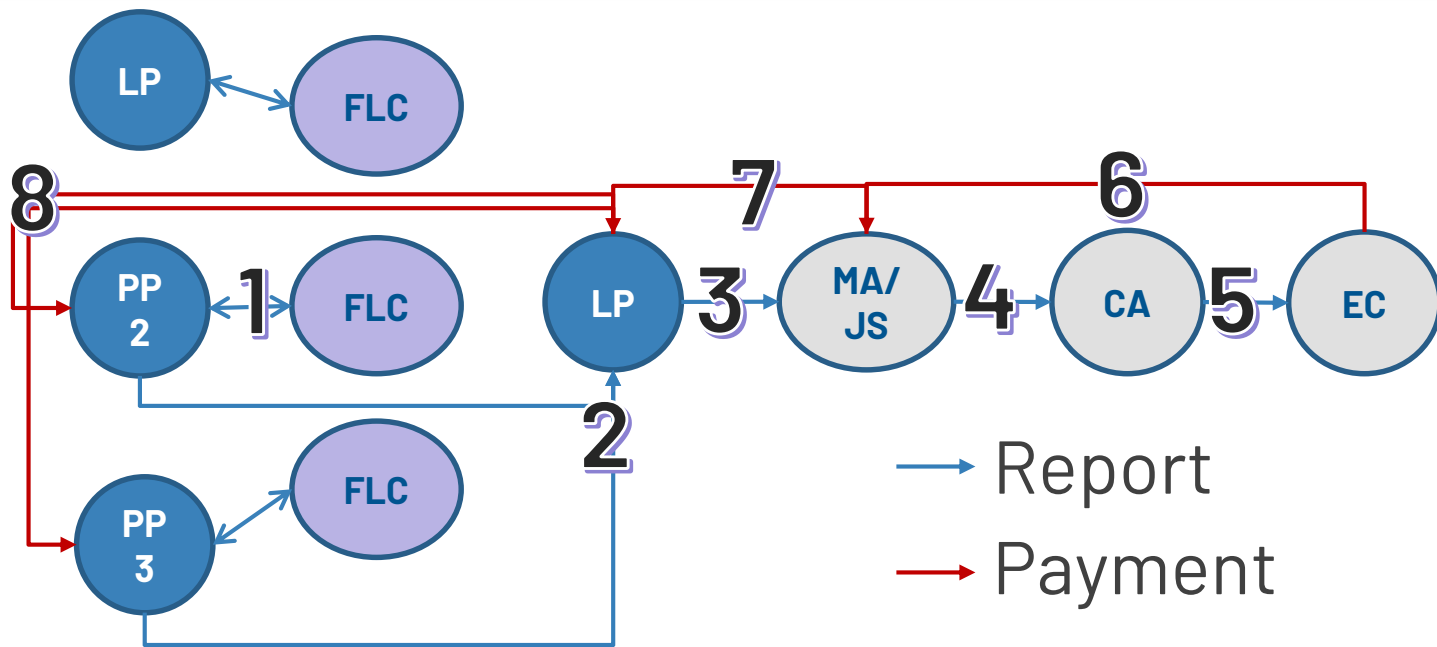

# Deadlines for reporting (& controlling)



- ✓ Subsidy contract sets 2 reporting deadlines:

<b>Expenditures incurred</b>	<b>Deadlines</b>	<b>Time for reporting + FLC</b>
01 Jan. yy – 30 Jun. yy	30 Sep. yy	60 working days
01 Jul. yy – 31 Dec. yy	31 Mar. yy+1	60 working days

- ✓ For FLC, beneficiaries have to plan sufficient time, e.g.:

<b>Steps</b>	<b>Necessary time</b>
Beneficiary collect documents, submits report to FLC	20 working days e.g.
FLC certifies + requests integrations etc.	30 working days e.g.
Lead partner reports (incl. all certificates to MA)	10 working days e.g.

# LEVELS OF CONTROL

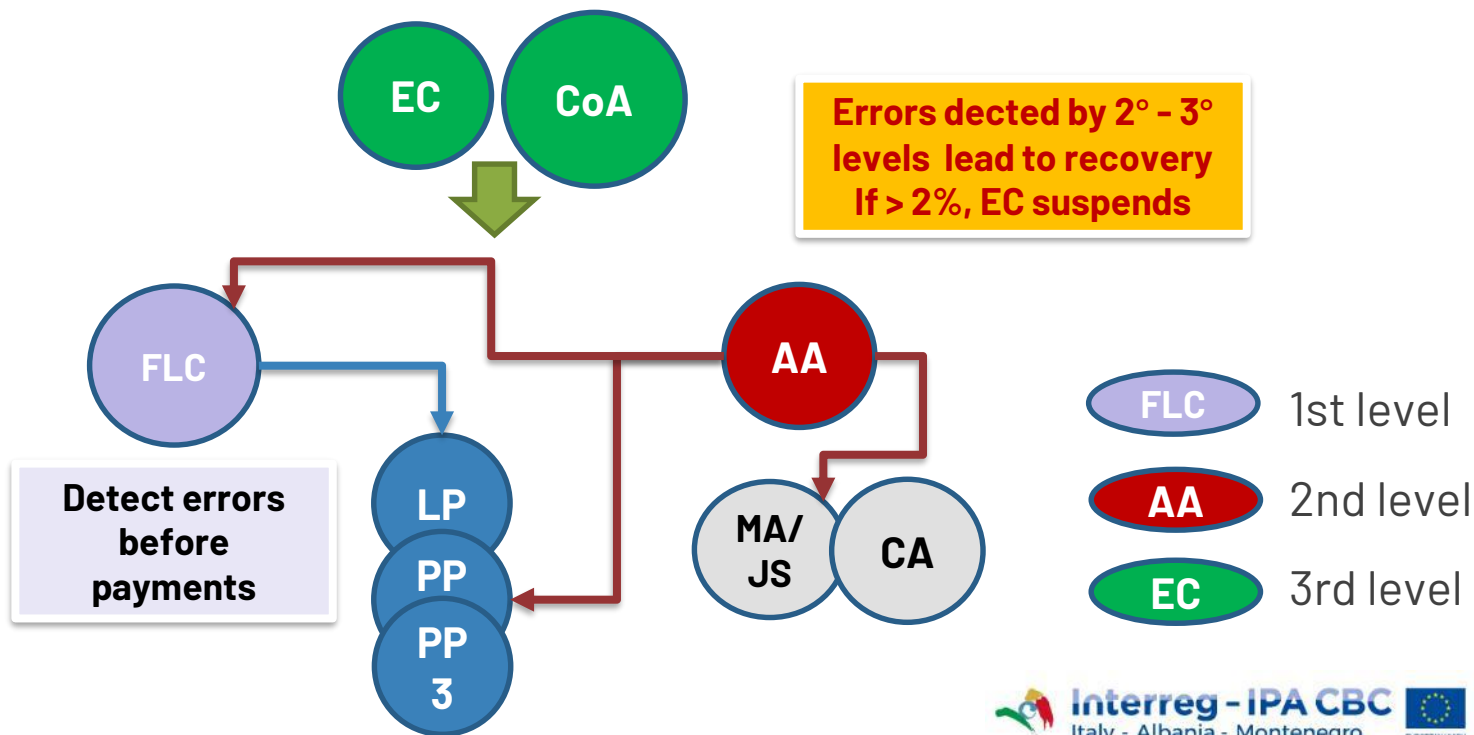



**Practice makes  
perfect**  
**EXIT TEST at**  
**[https://forms.gle/Tj8  
tiESWDGt78ZhW7](https://forms.gle/Tj8tiESWDGt78ZhW7)**



**Interreg - IPA CBC**  
Italy - Albania - Montenegro

